

SkyAzúl

EQUIPMENT SOLUTIONS

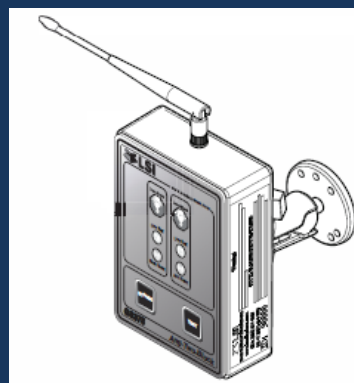

GS375 Display And Anti-Two-Block



INSTALLATION AND OPERATOR'S MANUAL

NOTICE

SkyAzúl makes no warranty of any kind with regard to this material, including, but not limited to, the implied warranties of merchantability and/or its fitness for a particular purpose.

SkyAzúl will not be liable for errors contained in this manual or for incidental or consequential damages in connection with the furnishing, performance, or use of this manual. This document contains proprietary information, which is protected by copyright, and all rights are reserved.

No part of this document may be photocopied, reproduced, or translated to another language without the prior written consent of SkyAzúl.

SkyAzúl reserves proprietary rights to all drawings, photos and the data contained therein. The drawings, photos and data are confidential and cannot be used or reproduced without the written consent of SkyAzúl. The drawings and/or photos are subject to technical modification without prior notice.

All information in this document is subject to change without notice.



SkyAzúl, Inc.
16 Walnut Street
Middletown, MD 21769
Fax 301-371-0029
info@skyazul.com

BEFORE PROCEEDING

Read and understand the following:

For your safety and that of the people that come into contact with **LSI** products, understand the significance of the instructions included in this guide, respect all laws and regulations and comply with applicable standards.

Pay particular attention to items bearing the alert symbol  and the following words:



WARNING!

Warning: this denotes an instruction that if not complied with may lead to serious injury or death.



CAUTION!

Caution: this denotes an instruction that if not complied with may lead to product failure or property damage.



IMPORTANT!

Important: this denotes an instruction that if not complied with may lead to product performance issues.



WARNING! Installation must be made in compliance with **LSI** instructions and using **LSI** supplied components only. Failure to install all parts, or replacing parts or components with parts or components not supplied by **LSI**, may lead to system failure, serious injury or death.

TABLE OF CONTENTS

1. INTRODUCTION

1.1 OVERVIEW	4
1.2 START-UP	4
1.3 RECOMMENDED OPERATING CONDITIONS	4

2. INSTALLATION

2.1 DISPLAY GS375.....	5
2.1a Mounting Bracket	5
2.1b Antenna Position	6
2.1c Power Supply and Lockout Connection	6
2.2 ANTI-TWO-BLOCK SWITCH	7
2.2a Switch Bracket Installation LB011	7
2.2b GS050 Installation	8
2.2c GS075B Installation	8
2.2d Chain length adjustment	8

3. OPERATION

3.1 SET THE ID NUMBER	10
3.1a Manually Set the ID Number - Procedure № 1.....	10
3.1b Manually Set the ID Number - Procedure № 2.....	10

4. MAINTENANCE

4.1 REPLACING THE ANTI-TWO- BLOCK BATTERY	11
4.1a Replacing the GS050 Batteries	11
4.1b Replacing the GS075B Battery	11
4.2 REPLACING THE SENSOR ANTENNA.....	12

5. CERTIFICATION NOTES

5.1 FCC AND IC – INSTRUCTIONS TO THE USER	13
5.2 CE	14
5.2a Declaration of conformity	14
5.2b CE Safety	14

6. LSI PRODUCT LIMITED WARRANTY - 2009/02/16

6.1 LIMITED WARRANTY	15
6.2 WARRANTY SERVICES PROCEDURES.....	15
6.3 EXCLUSION OF OTHER WARRANTIES	15
6.4 EXCLUSION	16
6.5 LIMITATION OF LIABILITY	16
6.6 RECOMMENDED PRACTICES	16
6.7 CHOICE OF LAW	16
6.7a Entire Agreement	16

1. INTRODUCTION

1.1 Overview

The anti-two-block indicator kit includes a GS375 display and one or two wireless anti-two-block switches. The GS375 creates a two-way radio network with the anti-two-block(s) to monitor status. When an anti-two-block switch goes from safe to alarm condition, the GS375 will activate its alarm and lockout wires within 0.05 seconds. The lockout wire can be connected to a relay to block crane functions such as boom out or hoist up.

1.2 Start-Up

On power up, the display will take between 5 and 10 seconds to communicate with the anti-two-block switch(es) it controls. All lights will be “on”. After this period, the main hoist green light should light up steady. If it flashes, it means communication is not established. See the section on changing batteries later in this manual, or the section on changing ID numbers if the switch has been changed.

The auxiliary hoist green light works the same as the main hoist green light, but it applies to the second anti-two-block switch, if present. The auxiliary hoist green light will stay “off” if the display is not programmed to communicate with a second anti-two-block switch.

1.3 Recommended Operating Conditions

Supply voltage:

9 to 30 volts

Current requirements:

maximum 1 amperes

Output wire voltage:

0 volts or supply voltage - 0.7 volts

Output wire current capability:

0.75 amperes

Operating temperature:

-40°C to +85°C (-40°F to 185°F)

2. INSTALLATION

WARNING! Installation must be made in compliance with **LSI** instructions and using **LSI** supplied components only. Failure to install all parts, or replacing parts or components with parts or components not supplied by **LSI**, may lead to system failure, serious injury or death.

2.1 Display GS375

IMPORTANT! Do not crack or puncture the membrane fascia. The GS375 display is splash and rain proof. Waterproofing depends in part on the integrity of the membrane.

IMPORTANT! Do not power wash the display. The GS375 display is not designed to withstand high-pressure washing devices that can erode the membrane fascia seal or create fissures in the membrane fascia. Power washing the display voids warranty coverage.

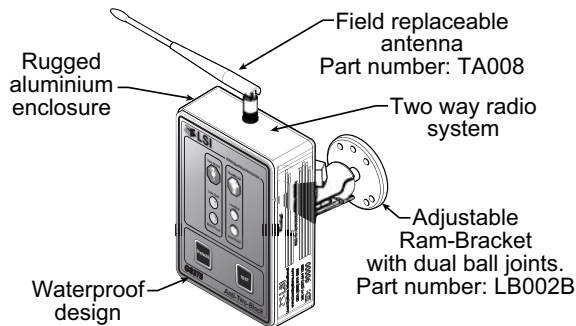

Figure: Display GS375

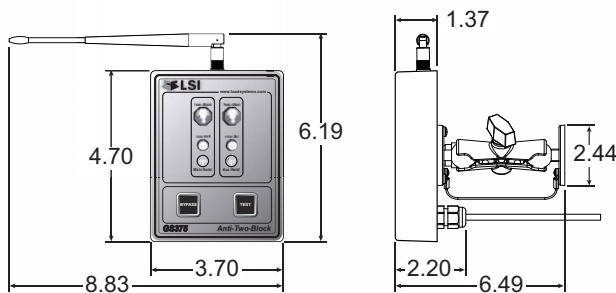

Figure: Display dimensions (inches). Not to scale.

2.1a Mounting Bracket

1. Determine the mounting location; the display may be installed either inside or outside the cab. It can be mounted on the dash, on a sidewall, or on the ceiling of the cab. **To ensure**

reliable radio communication between anti-two-block switch and the GS375, the antenna should not be in contact with metal and should have a direct and clear line of sight to the sensor antenna. The mounting bracket requires a flat surface of at least 2.5 inches in diameter on both sides and where the back of the surface is accessible in order to tighten the nuts.

2. Drill 1/4 inch boltholes through the mounting surface with a 1/4 inch bit following either the two, three, or the four holes configuration.

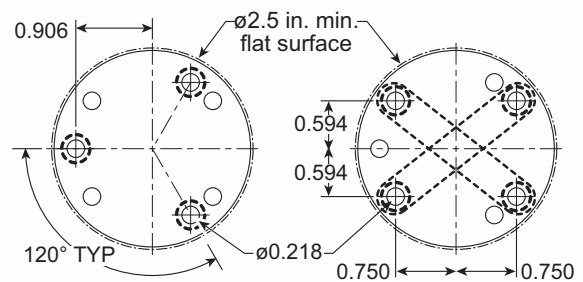

Figure: Display mounting bracket footprint. Not to scale.

3. Install the display with bolts. Add washers and lock nut behind the mounting surface and tighten sufficiently (bolts, nuts and washers not included).

Note: If the nuts are on the outside of the cab, caulk with silicone between the washers and the cab to prevent water entry.

4. Loosen the wing nut of the bracket arm to adjust display orientation to facilitate viewing by the operator and then tighten it back up.

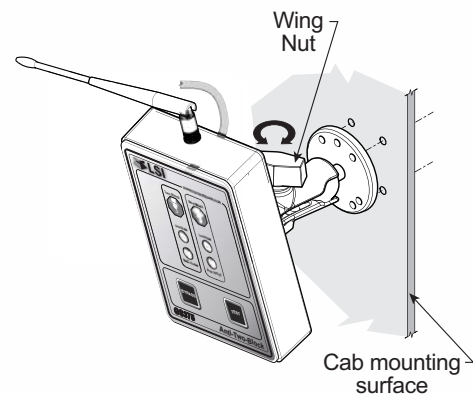

Figure: Install the display and adjust orientation

2.1b Antenna Position

For optimal performance the antenna should be positioned on its side such that it is parallel to the sensor antenna (but not pointing directly to or directly away from it).

1. Adjust the antenna position with the articulating base.
2. The antenna should have 5 inches of clear space all around it.
3. The antenna should have an unobstructed line of sight to all sensor antennas at all boom angles.

2.1c Power Supply and Lockout Connection

1. Connect the blue wire (ground) to the negative terminal of the battery or the panel connection; alternatively bolt the blue wire to the body of the machine with a 1/4 inch or 5/16 inch bolt. The ground connection must be strong enough to sustain 3 amperes.
2. Connect the red wire to a fused accessory source, rated at least 3 amperes, that supplies +12 or +24 volts when the machine is in use. The GS375 will automatically detect the voltage level and adjust itself.
3. Lockout wire (if required): connect the green wire to a Bosch relay coil terminal. Connect the other coil terminal of the relay to the ground. When in safe condition, the green wire will energize at the battery positive level.
Current over 1 ampere on the green wire triggers an auto re-settable fuse. Current flow will resume several seconds after the short circuit is eliminated.

Troubleshooting: if no voltage is present on the green wire remove the load connected to it.

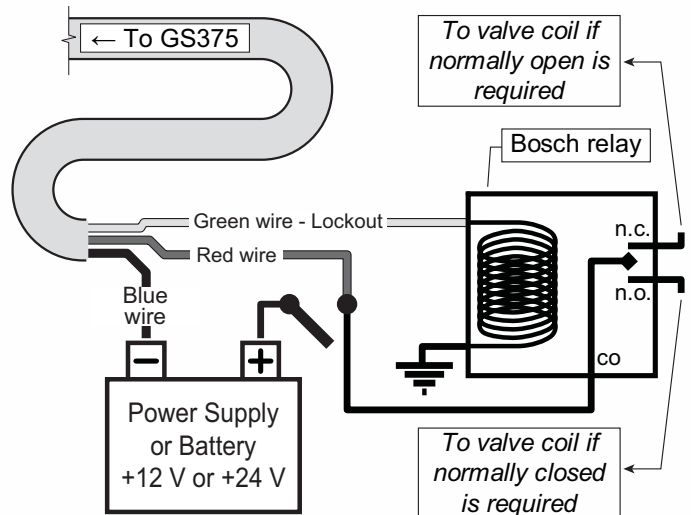

Figure: Connection with green wire lockout and recommended Bosch relay.

2.2 Anti-Two-Block Switch

WARNING! Keep the anti-two-block switch away from the boom and any connecting metal structures when welding mounting brackets to the boom. Proximity to welding may cause permanent damage to the anti-two-block switch and render the anti-two-block system unsafe.

IMPORTANT! To ensure reliable radio communication between the anti-two-block switch and the GS375 display the following conditions must be respected:

- The antenna of the anti-two-block switch should not be in contact with metal.
- The anti-two-block switch antenna should point to the left or to the right of the boom; it should not point directly to, or away from, the GS375 display.
- The anti-two-block switch antenna should have a clear line of sight to the GS375 display; in most cases this means mounting the sensor on the same side of the boom as the operator's cab.

Verify the anti-two-block switch is programmed to the GS375 display. Switches shipped with displays are pre-programmed in the factory. **Test:** if the switch has been programmed to the display then the display will go in to two-block alarm when the wire rope of the switch is released. Press **Bypass** to silence the alarm until the next two-block event or simulation. If the switch has not been programmed to the display, this should be done before proceeding with installation. See the section **3.1 Set the ID Number.**

2.2a Switch Bracket Installation LB011

1. Position the sensor mounting bracket. To ensure that the sensor can pivot securely on the mounting bracket throughout the full range of boom angle, the mounting bracket must be positioned at a 30° from horizontal with the boom parallel to the ground and such that the locking pin of the mounting bracket points up. **Bolt or weld securely.**

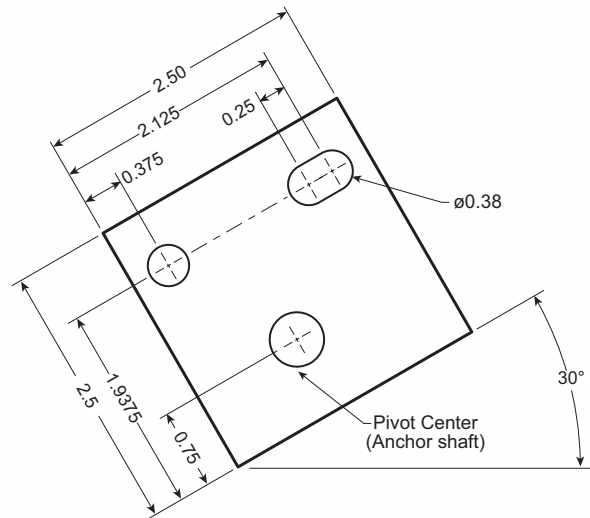

Figure: Bracket footprint and orientation, All dimensions are in inches. Not to scale.

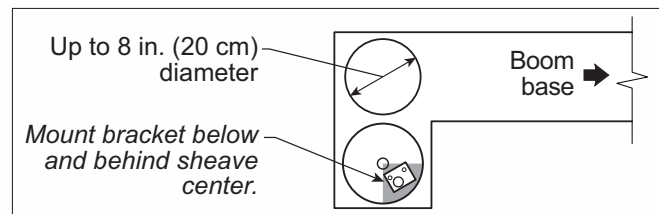

Figure: Anti-two-block switch placement on a telescopic boom

If the head sheave diameter is between 8 and 16 inches (20-41 centimetres) then two mounting brackets will be required to permit both live and dead end mounting.

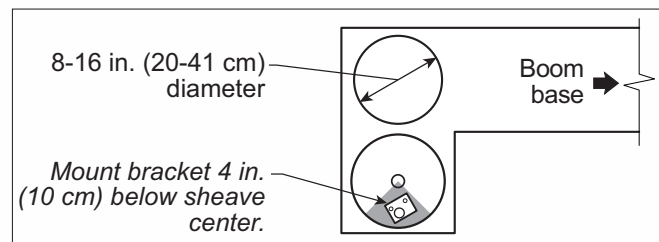

Figure: Anti-two-block switch placement for live end mounting on a lattice boom

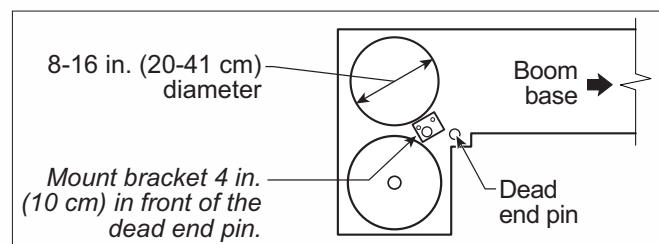

Figure: Anti-two-block switch placement for dead end mounting on a lattice boom

For live end mounting on multiple sheave blocks with sheaves greater than 16 inches (41 centimetres) in diameter consult your service representative.

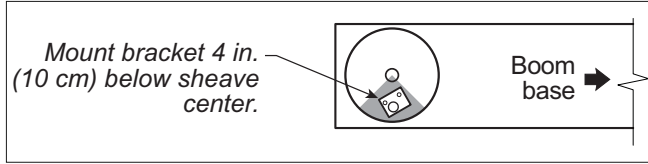

Figure: Jib, rooster or other extension; anti-two-block switch placement for single part of line operation only

For fast line weight installation place the anti-two-block switch mounting bracket directly below the sheave center as low and as close to the edge of the sheave as possible. Place the fast line weight mounting bracket on the opposite side of the sheave with the chain hole pointing down and lined up opposite the pivot of the anti-two-block switch mounting bracket.

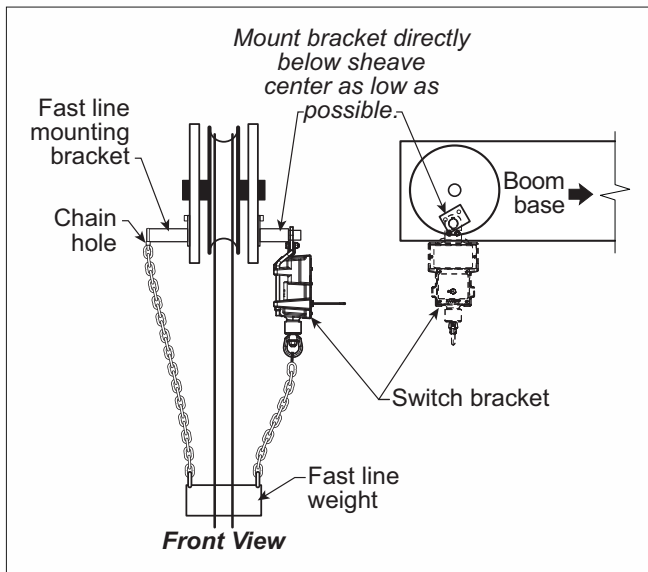

Figure: Fast line weight installation

2.2b GS050 Installation

1. Mount the GS050 on the bracket and verify that the GS050 can rotate freely through all possible boom movements without being able to come off the bracket.
2. Install the weight and chain assembly around the cable and attach the other end of the chain to the GS050. Tighten all the chain links of the chain assembly.
3. Adjust chain length as required, see sub-section **Chain length adjustment**.
4. Test system function.

2.2c GS075B Installation

1. Install the GS075B on the LB011 (switch bracket) already installed on the crane boom (step 2.2a), with the antenna pointing away from the boom.
2. Install a weight and chain assembly to the eye nut. The weight and chain assembly can either be supplied by LSI (as an option) or the original assembly supplied with the crane. If the original assembly is to be used, its total weight must not be more than 13lb.

2.2d Chain length adjustment

1. Chain length adjustment № 1 – minimum boom angle
 - a. At minimum boom angle, with no additional weight on the hook block and one part of line only, lift the boom just enough to have the hook block off the ground and clear the sensor chain and weight.

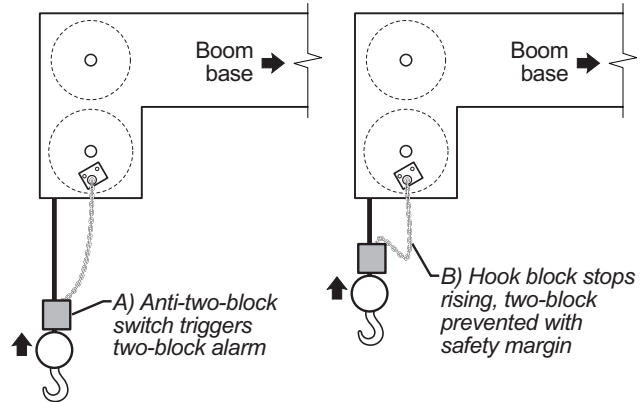

Figure: Chain length adjustment - Minimum boom angle

- b. Hoist slowly until the buzzer sounds. Note the hoisting distance remaining; this distance must be great enough to allow the operator and the lockout system, if installed, to prevent a two-block event. If necessary, add chain between the sensor and weight to increase warning distance. If still insufficient, contact your service representative.
2. Chain length adjustment № 2 – maximum boom angle
 - a. Raise the boom to the maximum angle.
 - b. Hoist slowly as described in **Step 1.b**. Verify that the warning distance is equal to or greater than that determined at the minimum boom angle.

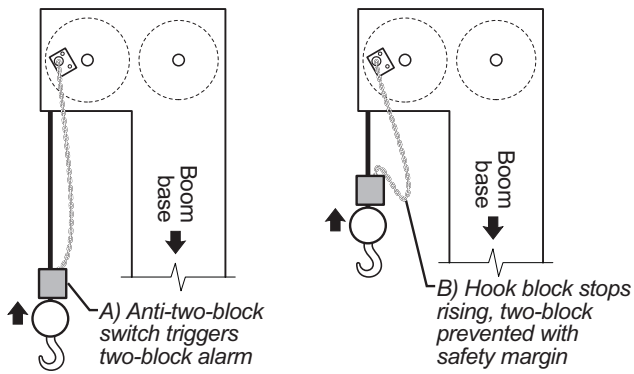

Figure: Chain length adjustment - Maximum boom angle

3. Chain length adjustment № 3 – speed test: Lower the boom until the weight height becomes visually clear to the operator. Repeatedly create two-block, progressively hoisting faster, to ensure that the warning and lockout work within acceptable amount of time and distance. Increase the length of the chain if needed.

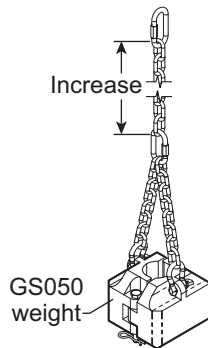

Figure: Chain length adjustment



IMPORTANT!

GS050: to increase chain length, only use lightweight chain.

3. OPERATION

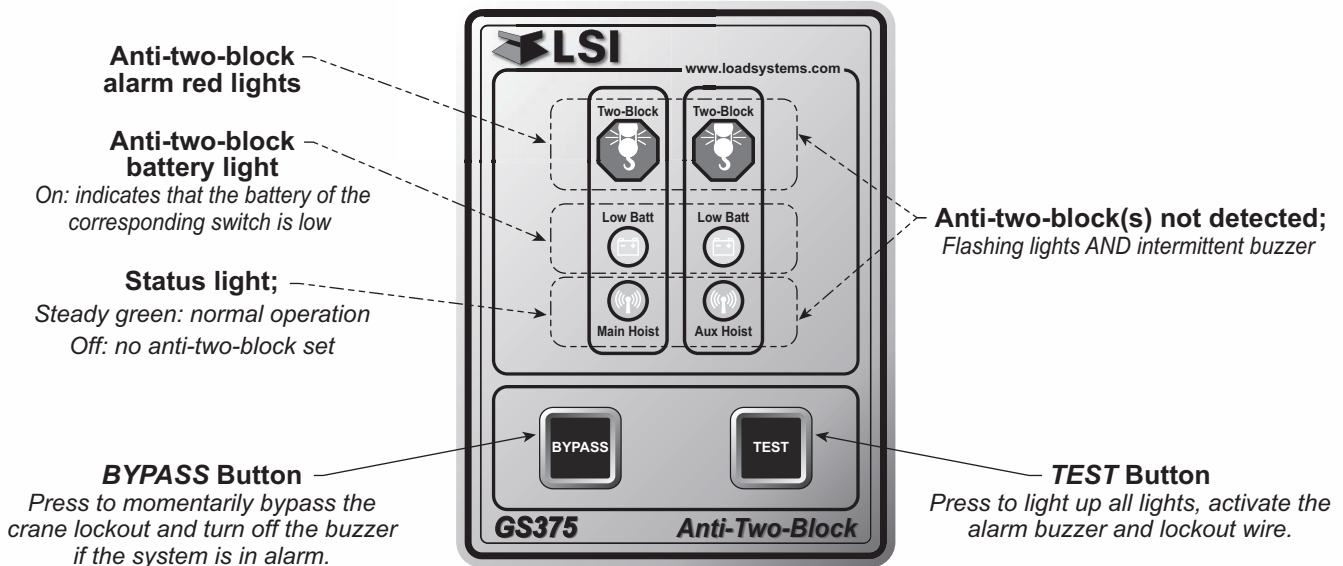

3.1 Set the ID Number

WARNING! Test the operation of each anti-two-block switches installed before every use.

Complete systems ship with the display and switch(es) pre-programmed together.

Replacement components may also be pre-programmed. However, if a display must be programmed on site two methods are available.

3.1a Manually Set the ID Number - Procedure No 1

Follow this procedure when the switch is not installed on the boom. Summary: re-set the switch with the display in learning mode.

1. Press the **Bypass & Test** buttons simultaneously until the display beeps (about 5 seconds). The "main hoist" light will flash, to indicate that a new main hoist anti-two-block can be registered.
2. Remove the battery from the main hoist anti-two-block switch and then re-insert the battery. The display should detect the new anti-two-block switch: it will beep and register the new ID number. The main hoist green light will stop flashing, the auxiliary hoist green light will start flashing. Repeat for the auxiliary hoist switch if required, or press the Bypass button to exit the learning mode.
3. **Test the programmed switch(es) to ensure the system functions as required.**

3.1b Manually Set the ID Number - Procedure No 2

Follow this procedure when the switch is already installed on the boom. Summary: simulate repeated two-blocks with the display in learning mode. Large numbers of GS series sensors within radio range may interfere with this method, especially if sensors are in alarm. In this case **Procedure No 1** may be preferable.

1. Press the **Bypass & Test** buttons simultaneously until the display makes a double beep, after about 10 seconds (ignore the single beep after 5 seconds). The "main hoist" light will flash.
2. Wait 10 seconds; the display is now listening ready to register a new main hoist anti-two-block switch. Simulate repeated two-blocks with the main hoist switch. The switch should change state, from safe to alarm and back, several times. The display beeps when the new main hoist id number has been registered. The auxiliary hoist light now flashes.
3. The display is now ready to register a new auxiliary hoist anti-two-block switch. Repeat two-block simulation with auxiliary hoist switch if required, or press the **Bypass** button to exit the learning mode.
4. Test all programmed systems for correct system function.

4. MAINTENANCE

4.1 Replacing the Anti-Two-Block Battery

IMPORTANT! Replace all the batteries of the anti-two-block switch at the same time. Unchanged batteries will reverse polarity severely reducing battery life.

IMPORTANT! Protect the interior of the sensor from dirt and humidity at all times.

IMPORTANT! Both lithium or alkaline batteries can be used, however lithium battery will last about 2.5 times longer.

4.1a Replacing the GS050 Batteries

IMPORTANT! Class I Div I sensors certified by CSA or ATEX should use alkaline batteries only.

IMPORTANT! Do not unscrew the white nylon hex bolt of the antenna.

IMPORTANT! Do not unscrew the small screw to the left of the antenna.

1. Remove the anti-two-block from the crane and clean off dust and grime.
2. Place the anti-two-block on the edge of flat surface. Use an adjustable wrench to unscrew the large white nylon hex bolt of the wire rope about one half-inch.
3. Carefully remove the plunger assembly without separating it from the cover, and place it on a clean and dry surface.
4. Slide out the four old batteries.

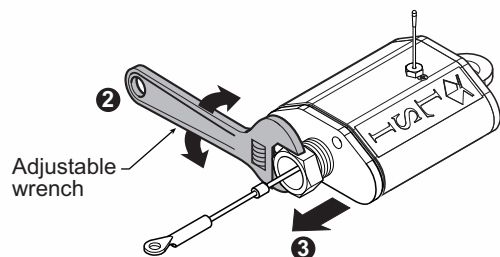

Figure: Remove the plunger assembly

5. Insert the four new batteries following the positive - negative schematic printed on the back of the sensor.

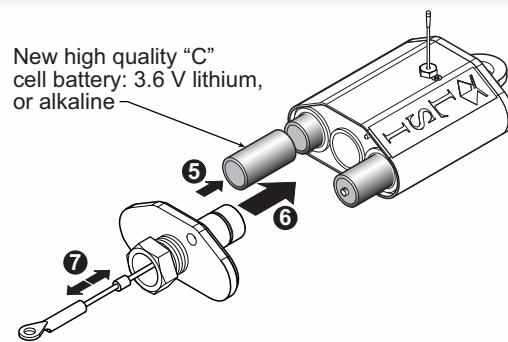

Figure: Install the new batteries and the plunger

6. Replace the plunger assembly. Correctly align the bottom cover before screwing in the white nylon hex bolt of the wire rope. Tighten well.
7. Pull and release the wire rope, the light emitting diode (LED) on the bottom of the sensor should flash red.
8. Reinstall the anti-two-block switch.
9. Test the anti-two-block system for alarm and lockout before operating the machine.

4.1b Replacing the GS075B Battery

1. Remove the GS075B anti-two-block from the crane and clean off dust and grime.
2. Unscrew the two screws of the battery cover and remove the battery cover.
3. Remove the battery by hand.
4. Insert the new battery following the positive - negative schematic.
5. Reposition the battery cover and screw in both screws.

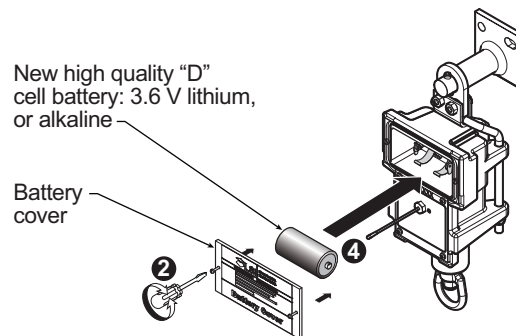

Figure: Replacing GS075B battery

6. Reinstall the anti-two-block switch.
7. Test the anti-two-block system for alarm and lockout before use.

4.2 Replacing the Sensor Antenna

Heavily damaged antennas (ripped out, sheared off, wire exposed and fraying etc.) should be replaced to ensure effective communication between the sensor and the cabin mounted display unit.

This procedure may be followed without removing the sensor from the crane if it is safe to do so.



IMPORTANT! The interior of the sensor must be protected from dust, grime and water at all times.

1. Place the crane, boom, jib or ball hook such that the sensor is safely accessible.
2. Clean dust, grime and water from the sensor.
3. Identify the short black whip antenna and the white hex bolt securing it.
4. Inspect the antenna for signs of obvious physical damage.
5. Carefully unscrew the white nylon hex bolt completely and slide it up the antenna.

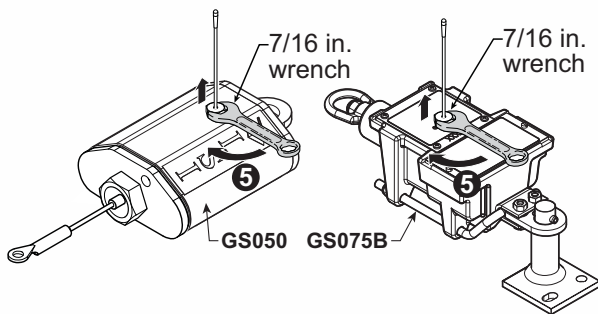

Figure: Unscrew the white nylon hex

6. Grip the antenna by the base of the black plastic sheathing and pull it straight out of the hole in which it is seated. Place the old antenna aside.

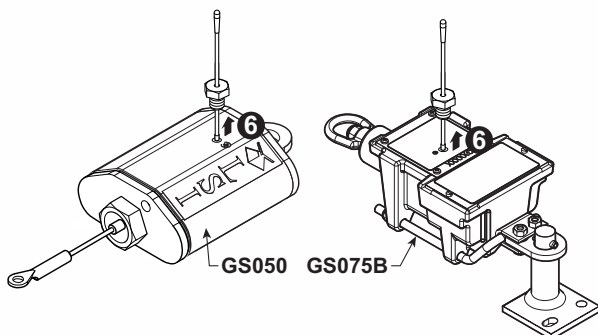

Figure: Pull out the antenna

7. Slide the white nylon hex bolt to the middle of the length of the new antenna.
8. Coat the exposed metal foot of the new antenna with an electrical insulating compound by carefully inserting it in the mouth of the compound tube.

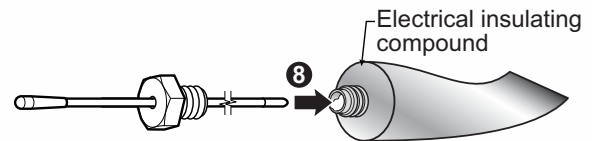

Figure: Coat the exposed metal foot of the antenna

9. Hold the new antenna by the black plastic sheathing and guide it through the hole in the sensor box. Carefully seat the antenna in its mating connector. When the antenna is correctly seated, pulling on it will be met with light resistance.

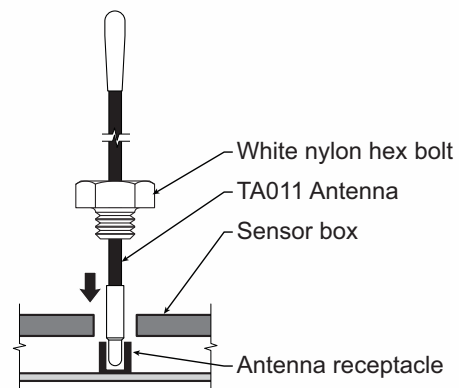

Figure: Install the new antenna

10. Carefully re-thread, screw-in and tighten the white nylon hex bolt to secure the antenna in place. **Do not overtighten.**
11. Reinstall the sensor if necessary.
12. Verify that the sensor functions properly.

5. CERTIFICATION NOTES

5.1 FCC and IC – Instructions to the User

This equipment has been tested and found to comply with the limits for a class B digital device, pursuant to part 15 of the FCC Rules. These limits are designed to provide reasonable protection against harmful interference in a residential installation. This equipment generates, uses, and can radiate radio frequency energy and if not installed and used in accordance with the instructions, may cause harmful interference to radio communications. However, there is no guarantee that interference will not occur in a particular installation. If this equipment does cause harmful interference to radio or television reception, which can be determined by turning the equipment off and on, the user is encouraged to try to correct the interference by one or more of the following measures:

- Reorient or relocate the receiving antenna.
- Increase the separation between the equipment and receiver.
- Connect the equipment into an outlet on a circuit different from that to which the receiver is connected.
- Consult the dealer or an experienced radio/TV technician for help.

In order to maintain compliance with FCC regulations, shielded cables must be used with this equipment. Operation with non-approved equipment or unshielded cables is likely to result in interference to radio and TV reception.

IMPORTANT! Changes or modifications to this equipment not expressly approved by the party responsible for compliance could void the user's authority to operate the equipment.

FCC ID: QVBGS300 IC: 7076A-ICGS300

RF Exposure Warning:

This product complies with FCC/IC radiation exposure limits set forth for an uncontrolled environment. To comply with RF exposure requirements, the unit must be installed and operated with 20 cm (8 in.) or more between the product and your body. This product may not be collocated or operated in conjunction with any other antenna or transmitter.

This device has been designed to operate with the antennas listed below, and having a maximum gain of 2.0 dB. Antennas not included in this list or having a gain greater than 2.0 dB are strictly prohibited for use with this device. The required antenna impedance is 50 ohms.

To reduce potential radio interference to other users, the antenna type and its gain should be so chosen that the equivalent isotropically radiated power (e.i.r.p.) is not more than that permitted for successful communication.

Antenna List

LSI P/N:TA008
Description: .1/2 wave dipole
MFG:Nearson
P/N:S467AH-915S

FCC ID: QVBGS000 IC: 7076A-ICGS000

FCC ID: QVBGS050 IC: 7076A-ICGS050

FCC ID: QVBGS075 IC: 7076A-ICGS075

RF Exposure Warning:

This product complies with FCC/IC radiation exposure limits set forth for an uncontrolled environment. To comply with RF exposure requirements, the unit must be installed and operated with 20 cm (8 in.) or more between the product and your body. This product may not be collocated or operated in conjunction with any other antenna or transmitter.

This device has been designed to operate with the antennas listed below, and having a maximum gain of 3.0 dB. Antennas not included in this list or having a gain greater than 3.0 dB are strictly prohibited for use with this device. The required antenna impedance is 50 ohms.

To reduce potential radio interference to other users, the antenna type and its gain should be so chosen that the equivalent isotropically radiated power (e.i.r.p.) is not more than that permitted for successful communication.

Antenna List

LSI P/N:TA011
Description: .1/4 wave monopole
MFG:Load Systems International

5.2 CE



5.2a Declaration of conformity

Declaration of Conformity According to EN 45014

Manufacturer's Name: Load Systems International Inc.

Manufacturer's Address:

Canada:
4495 Blvd. Wilfrid-Hamel, Suite 110
Québec, QC, Canada, G1P 2J7

United States of America:
9223 Solon, Suite A
Houston, TX 77064

United Arab Emirates:
Q3-171 SAIF Zone, P.O. Box 7976
Sharjah - UAE

declare under our own responsibility that the products:

Model	Description
GC005-CE, GC005-ATEX-CE	5 000 lb Capacity Load Cell
GC012-CE, GC012-ATEX-CE	12 000 lb Capacity Load Cell
GC018-CE, GC018-ATEX-CE	18 000 lb Capacity Load Cell
GC035-CE, GC035-ATEX-CE	35 000 lb Capacity Load Cell
GC060-CE, GC060-ATEX-CE	60 000 lb Capacity Load Cell
GC100-CE, GC100-ATEX-CE	100 000 lb Capacity Load Cell
GC170-CE, GC170-ATEX-CE	170 000 lb Capacity Load Cell
GS001-CE, GS001-ATEX-CE	Load Transmitter With Pigtail 6 in.
GS002-CE, GS002-ATEX-CE	Load Transmitter With Pigtail 6 in for balanced cell
GS005-CE, GS005-ATEX-CE	Anti-Two-Block Transmitter
GS010-XX-CE, GS010-XX-ATEX-CE	Angle Sensor
GS011-XX-CE, GS011-XX-ATEX-CE	Angle Sensor With Length Input
GS012-CE	Angle Length Sensor
GS020-CE, GS020-ATEX-CE	Wind Speed Sensor
GS035-CE	Pressure Transducer
GS050-CE, GS050-ATEX-CE	Anti-Two-Block Sensor
GS075-CE	All-In-One Anti-Two-Block Switch Weight
GS2XX-CE	LSI Wireless Gateway
GS320-CE	Stand Alone Wind Speed Display
GS375-CE	Stand Alone A2B Display
GS550-CE, GS550-ATEX-CE	Standard GS display
GS550-03-CE	Hand-Held GS display
GS550-XX-CE	OEM GS display
GS820-CE	Graphical GS display

to which this declaration refers conform to the relevant standards or other standardising documents:

Safety: IEC 61010-1: 2nd ed. (2001), EN 61010-1: 2nd ed. (2001)

Wireless: EN 300 220-3 V1.1.1 (2000-09)

EMC: EN 301 489-3 V1.4.1 (2002-08)

Québec, April 1st, 2010

Eric Beaulieu
Technologies Manager

5.2b CE Safety

WARNING! When captors are used, the ambient temperature should not be higher than 84°C and the display should not be used when the ambient temperature is higher than 59°C, otherwise there can be a burn possibility.

WARNING! For the operator's safety, take only the ambient temperature range into consideration. The device should be used within this range specified above.

WARNING! The protection will be impaired if the material and equipment are used in a manner not specified by the manufacturer.

IMPORTANT! The IP of equipment corresponds to 65.

6. LSI PRODUCT LIMITED WARRANTY - 2009/02/16

6.1 Limited Warranty

LOAD SYSTEMS INTERNATIONAL INC. (hereafter "**LSI**") warrants its products (the "Products"), for a period of twenty four (24) consecutive months after delivery of such Products to the user (as evidenced on a **LSI** document) (the "Warranty Period"), when installed and used in accordance with specifications described in **LSI** Installer and User's Manual, as amended from time to time, **LSI** technical materials and any related writings published by **LSI** with respect with such Products and any industry standards, will be free from defects in materials and workmanship. During the Warranty Period, **LSI** or its designated service representative shall repair, or at its option, replace any Product that is confirmed to be defective by **LSI**, in its sole discretion, in accordance with the Limited Warranty Services Procedures described below.

6.2 Warranty Services Procedures

In order to benefit of this-mentioned Limited Warranty coverages and benefits, the purchaser must notify **LSI**'s customer service or **LSI**'s authorized distributor or representative originally responsible for the sale of the Products within 10 days of the occurrence of a suspected defect in materials or workmanship, prior to the expiry of the Limited Warranty Period in order to obtain a Return Authorization Number. A proof of purchase of the Product, such as an invoice or a receipt certifying the validity of the Warranty, must be presented in order to obtain Limited Warranty coverage. In any event, even if a Return Authorization Number is provided to purchaser, **LSI** reserves the right to inspect the damaged Product or part before the final decision of repairing or replacing the defective Product or part.

The Product or part shall be returned to **LSI** or its designated service representative, accompanied by the Return Authorization Number with prepaid shipping charges. The purchaser must insure the shipment or accept the risk of loss or damage during the shipment. Purchaser shall also pay any tariff or duty applicable to the return of defective part or Product. **LSI** will, at its option, repair or replace the Product or part returned to **LSI** or to its designated service representative. **LSI** owns all parts or Products replaced, repaired or removed from a repaired Product. If **LSI** repairs a Product, the Product

Warranty coverage Period is not extended and the Limited Warranty shall expire as if uninterrupted upon the occurrence of the 24th month from shipping from **LSI**. If **LSI** replaces a Product, the replaced Product is warranted for the remainder of the original term or sixty consecutive (60) days, whichever is longer.

LSI reserves the right to require from you the user or owner of the Products, prior to determining if the Limited Warranty coverage is applicable, that **LSI** receive the data logging equipment used with the Products and that **LSI** be authorized to retrieve all information from such data logging equipment in order to, among others, ensure that the written instructions and applicable standards, including safety margins, were respected and not exceeded during Product use. Failure by you the owner or user of the Product to supply such information shall be deemed a material default of the terms and conditions of this Limited Warranty and shall be irrevocably construed as evidence that the Product was misused or abused. Consequently **LSI** shall irrevocably be relieved of any obligations to compensate you the user or owner of the Product for any and all damages resulting from Product failures when data logging equipment, and access to its content, cannot be freely and readily provided, unhampered, to **LSI**.

LSI will pay ground freight transportation costs of replacement or repaired parts or Products to the destination in Canada and the continental United States of America (the "Territory"). LSI will not pay any transportation costs of replacement or repaired parts to destination outside of the Territory. Shipping and handling costs to locations outside the Territory shall be the responsibility and borne by Purchaser or Owner of the Product prior to any shipment by LSI. (Contact LSI to get a Return Authorization Number and the address to ship parts).

6.3 Exclusion of Other Warranties

THE ABOVE WARRANTY IS THE SOLE WARRANTY APPLICABLE AND THERE ARE NO EXPRESS, LEGAL OR IMPLIED WARRANTIES OR CONDITIONS IN RELATION TO ANY PRODUCTS INCLUDING ANY IMPLIED WARRANTY OR CONDITION OF MERCHANTABILITY, NON-INFRINGEMENT OR FITNESS FOR A PARTICULAR PURPOSE AND THOSE OTHERWISE ARISING BY STATUTE OR OTHERWISE IN LAW OR FROM A COURSE OF

DEALING OR USAGE OF TRADE, WHICH ARE EXPRESSLY DISCLAIMED. NO ORAL OR WRITTEN INFORMATION OR ADVICE GIVEN BY **LSI** OR ITS EMPLOYEES OR REPRESENTATIVES SHALL CREATE A WARRANTY OR CONDITION OR IN ANY WAY INCREASE THE SCOPE OF **LSI'S** OBLIGATION. **LSI** DOES NOT WARRANT THAT THE BUSINESS RESULTS OBTAINED FROM THE USE OF THE PRODUCTS WILL BE APPROPRIATE OR ADEQUATE FOR THE PURCHASER.

6.4 Exclusion

This Limited Warranty does not cover and shall not apply to:

- Any Product that is misused or abused, including being altered, modified or repaired not in accordance to **LSI** written instructions or authorizations and any use not in compliance with **LSI's** instructions and/or industry standards and practices;
- Any incidental costs or expense, such as shipping charges to **LSI** or an designated service representative as well as the technician out-of-pocket expenses including traveling, lodging and meal expenses, if any;
- The damages caused during the transport or the moving of the Products;
- Damages caused by accidents, abuse, misuse, a force majeure (described as events outside a **LSI's** or any Product user's control, including war, riot, strikes, embargoes) or external cause;
- Any cost, damage or expenses for field labor or any other expenses related to or arising from the replacement of defective parts.
- Products used for pile-driving, wire rope activated clamshell or dragline applications. If purchaser uses the Products for pile-driving, wire rope activated clamshell or dragline application, the limited warranty will be deemed to have been violated for abuse.
- Any costs associated with providing **LSI** with data logging equipment.

6.5 Limitation of Liability

To the maximum extent permitted by applicable law, in no event will **LSI** be liable to the purchaser or any third party for any indirect, special, consequential, incidental or exemplary damages whatsoever, including but not limited to loss or revenue or profit, lost or damaged data, business interruption or any other pecuniary loss whether based in contract, tort or

other causes of action, even if **LSI** has been advised of the possibility of such damages. In any event, the total liability of **LSI** arising from any cause of action or claim whatsoever, whether (1) in contract, (2) in tort (including negligence, whether sole, joint, contributory, concurrent or otherwise, but not including intentional, reckless or wanton tort), (3) under strict liability, (4) under any environmental or antipollution law or regulation, (5) connected with any toxic or hazardous substance or constituent, (6) arising out of any representation or instruction, or under any warranty, (7) or otherwise, arising out of, connected with, or resulting from the design, manufacture, sale, resale, delivery, repair, replacement or use of Products or the furnishing of any service shall in no event exceed the price allocable to and paid to **LSI** for the individual unit of Products or service or part thereof which gives rise to the cause of action or claim.

SOME STATES OR JURISDICTIONS DO NOT ALLOW THE LIMITATION OR EXCLUSION OF LIABILITY FOR INCIDENTAL OR CONSEQUENTIAL DAMAGES, SO THE ABOVE LIMITATION OR EXCLUSION MAY NOT APPLY TO YOU.

6.6 Recommended Practices

LSI recommends careful consideration of the following factors when specifying and installing the Products. Before installing a Product, the Installation, Operation, and Maintenance instructions provided with the unit must be read and understood and complied with.

6.7 Choice of law

This Limited Warranty shall be governed by and construed in accordance with the laws of : 1. For Products sold in Canada: the Province of Quebec or, For Products sold in the USA: the State of Florida, without giving effect to principles of conflicts of law. You agree that the exclusive venue for any disputes arising under this Agreement shall be the state and federal courts located in Orlando, Florida.

6.7a Entire Agreement

This document contains the entire agreement of the parties regarding the subject matter of the Product and supersedes all previous communications, representations, understandings and agreements, either oral or written, between you and **LSI**.



www.skyazul.com

SkyAzúl, Inc.
16 Walnut Street
Middletown, MD 21769
Phone 301-371-6126
Fax 301-371-0029
info@skyazul.com